

Eshteal Arak Industrial Engineering Company is the only manufacturer of high-capacity rotary cup burners in the country, and these burners are used by all boiler companies in the country. Among the unique products produced by this company are power valves that are designed for saturated and superheated steam lines. This product was produced for the first time in the country in 2014 in the Mobarake steel complex and at a pressure of 70 bar. It has been used successfully. Eshteal Arak Industrial Engineering Company has been modernizing its production lines since 2003 and is currently equipped with more than 98 machines, 61 of which are CNC lathes and milling centers (referred to at the end), stepped into the field of producing products with modern sophisticated technology. It should be mentioned that this company has succeeded in obtaining the knowledge-based badge on burners and valves during two consecutive periods, and in order to enhance the brand and satisfy customers, the necessary standards such as ISIRI 7595, ISIRI 7594, ISO 3834, ISO 9001:2015 and implemented 5S



water level controller is a comprehensive range of magnetically operated water level controls.

Water Level Controller BD



ESHTEAL ARAK

INDUSTRIAL ENGINEERING CO.
Manufacturer of burners, valves
and precision tools for steam boilers

☎ 086-34121313-5

☎ 09908136277 (sales)
☎ 09912709038 (after sales)

☎ 086-34131217

✉ eshteal.arak@gmail.com
✉ eshteal.commerce@gmail.com

📷 eshtearak

📍 Factory: Hadid St-Haji Abad Industrial Zone 7th km
of Qom Road-Arak-Iran

📍 Head office: 4th floor-No.3 Apartment Asef Vaziri
alley southern Bahar St Taleghani St-Tehran-Iran

Water Level Controller

Type BD (Direct Mounted Models)

Description

BD water level controller is a comprehensive range of magnetically operated water level controls. They are designed to meet all the requirements for automatic on/off control of boiler feed pump, burner cut-out, high and/or low level alarm or any combination of these Direct Mounted Vertical Air Brake Controls employ the same principles of operation and piece parts as the chamber mounted equivalents except that the chamber is exchanged for a large round flange and the tube assembly for mounting the control directly on to the boiler shell connection.



Operation

A primary permanent magnet attached to the float rod slides vertically inside a non-magnetic stainless-steel center tube and transmits the movements of the float to a secondary magnet in each switch unit. There are two pairs of contacts which are operated with a snap action and held by repulsion between the secondary magnet and the tertiary magnet of the switch unit assembly.

Limiting conditions

Maximum working pressure is 20 bar.

Dimensions and pipe connections

Dimensions (approx.) in mm

Type number	Maximum working pressure at saturated steam (bar)	Operating Range (mm)	No. of switches	Dimensions						
				Flanged connections BS 4504 (PN40)				L*	H	D1
				D	N	O	P			
BD 01/1	12	62	1	235	8	22	190	-	200	
	20								89	
BD 02/2	12	150	2	235	8	22	190	-	300	
	20									

* The Dimensions Can Be Changed According To The Installation Conditions.

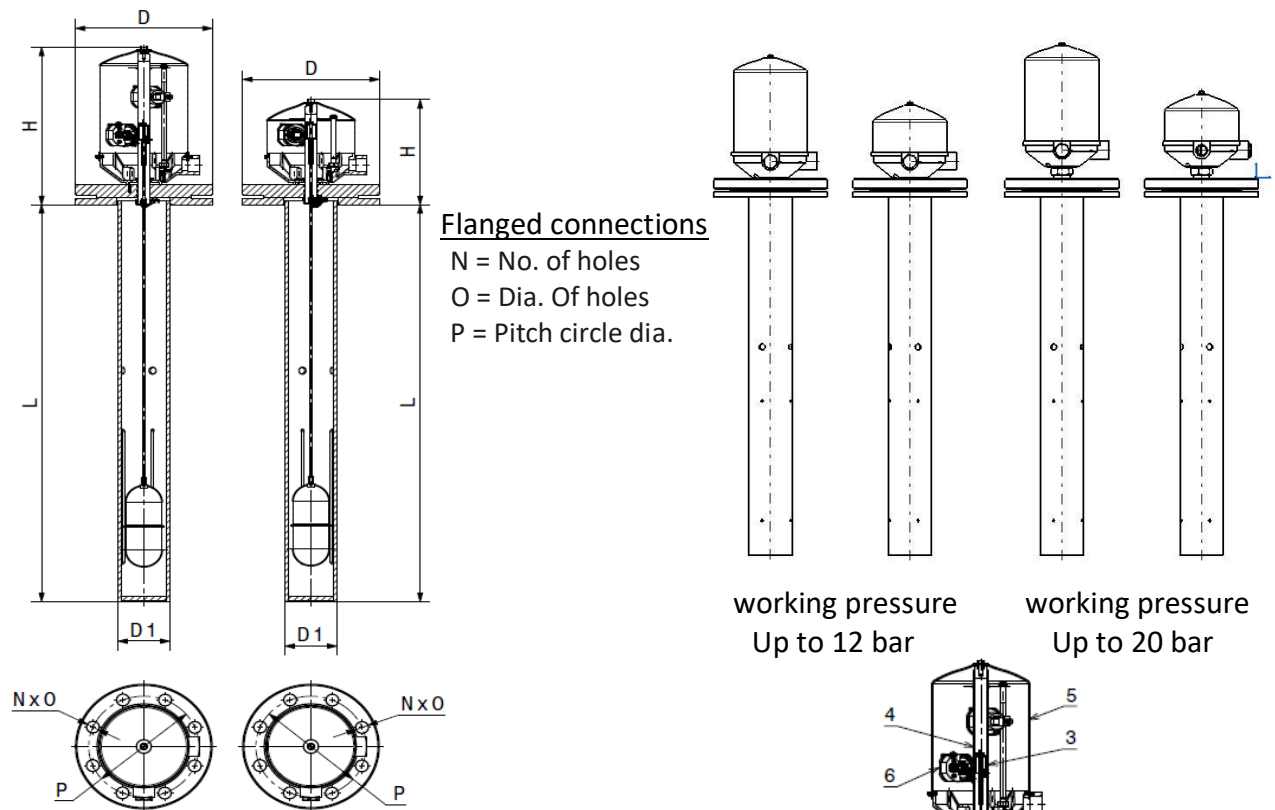

Material

Item	Part name	Material
1	Flange	St 52
2	Stop cap	Stainless Steel
3	Magnet	-
4	Center tube	Stainless Steel
5	Switch head	Aluminum
6	Switch units	Cast ceramic
7	Float road	Stainless Steel
8	Float	Stainless Steel